

220136_bp_landscape.dwg (7/2020)

LEGEND

BUILDING	
PROPERTY LINE W/ BEARING DISTANCE	S81°56'34"E 116.23'
CONTOUR	- - - - - 70 - - - - -
STOCKADE FENCE	
CHAINLINK FENCE	
PICKET FENCE	
SEWER LINE	S
DRAIN LINE	D
WATER LINE	W
GAS LINE	G
GAS VALVE	
WATER VALVE	
DRAIN MANHOLE	
SEWER MANHOLE	
CATCH BASIN	
UTILITY POLE	
LIGHT POLE	
DECIDUOUS TREE	DEC. 22"
CONIFEROUS TREE	CON. 12"
FIRE HYDRANT	
PROPOSED PLANTING	
PROPOSED PERENNIAL PLANTING	

BUFFER ZONE RESTORATION AREA (2,250s.f.)

Qty	Symbol	Botanical Name
5	(A)	Acer rubrum
5	(O)	Quercus rubra
4	(AC)	Amelanchier canadensis
6	(AM)	Aronia melanocarpa
4	(CR)	Cornus racemosa
4	(HV)	Hamamelis virginiana
6	(CA)	Clethra alnifolia
8	(IG)	Ilex glabra
4	(MP)	Myrica pensylvanica
4	(VT)	Viburnum trilobum

LAWN ENHANCEMENT AREA (465.0s.f.)

Qty	Symbol	Botanical Name
3	(CR)	Cornus racemosa
3	(HV)	Hamamelis virginiana
3	(CA)	Clethra alnifolia
3	(VA)	Viburnum acerifolium
3	(LB)	Lindera benzoin

LANDSCAPE PLANTINGS/HEDGE

Qty	Symbol	Botanical Name
47	(*)	mixed perennials
11	(JV)	Juniperus virginiana
9	(CG)	Calamagrostis acutifolia

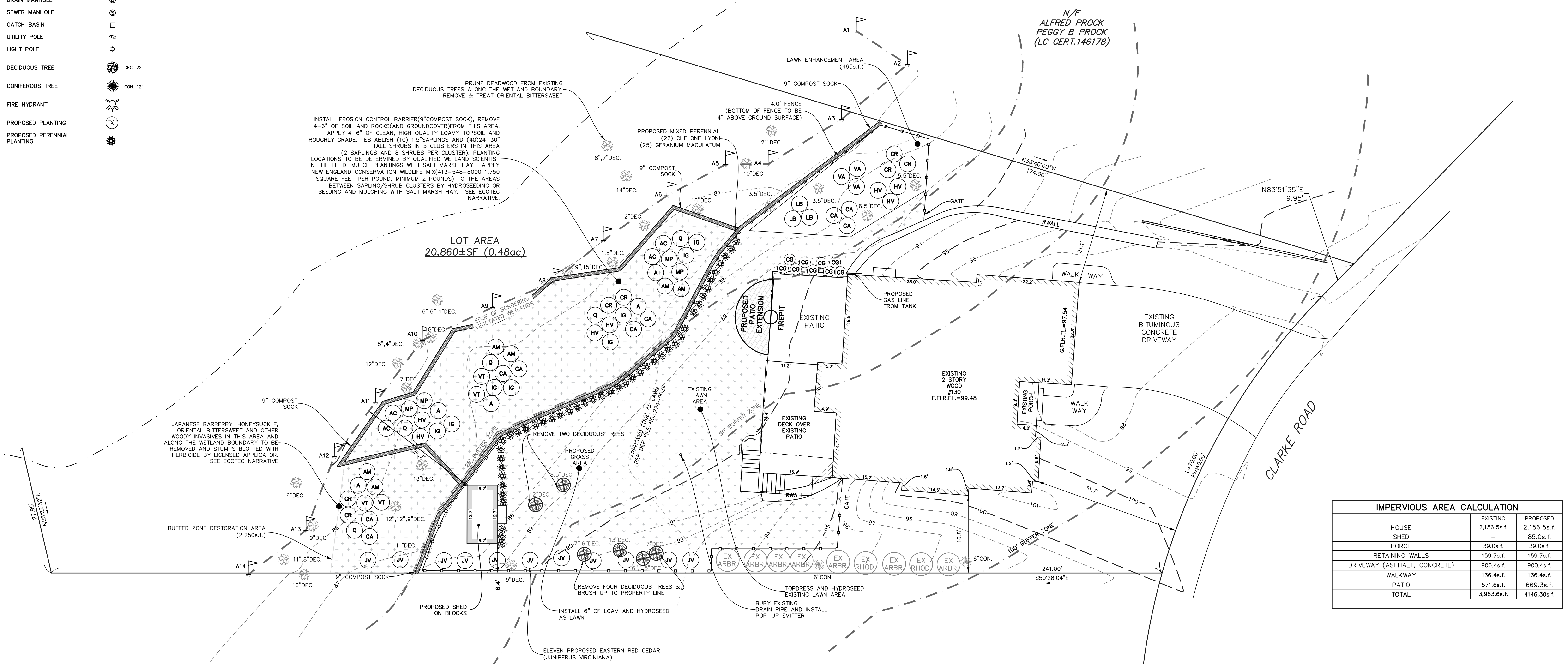

IMPERVIOUS AREA CALCULATION

	EXISTING	PROPOSED
HOUSE	2,156.5s.f.	2,156.5s.f.
SHED	-	85.0s.f.
PORCH	39.0s.f.	39.0s.f.
RETAINING WALLS	159.7s.f.	159.7s.f.
DRIVEWAY (ASPHALT, CONCRETE)	900.4s.f.	900.4s.f.
WALKWAY	136.4s.f.	136.4s.f.
PATIO	571.6s.f.	669.3s.f.
TOTAL	3,963.6s.f.	4146.30s.f.

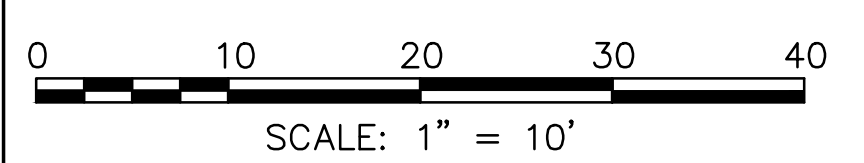
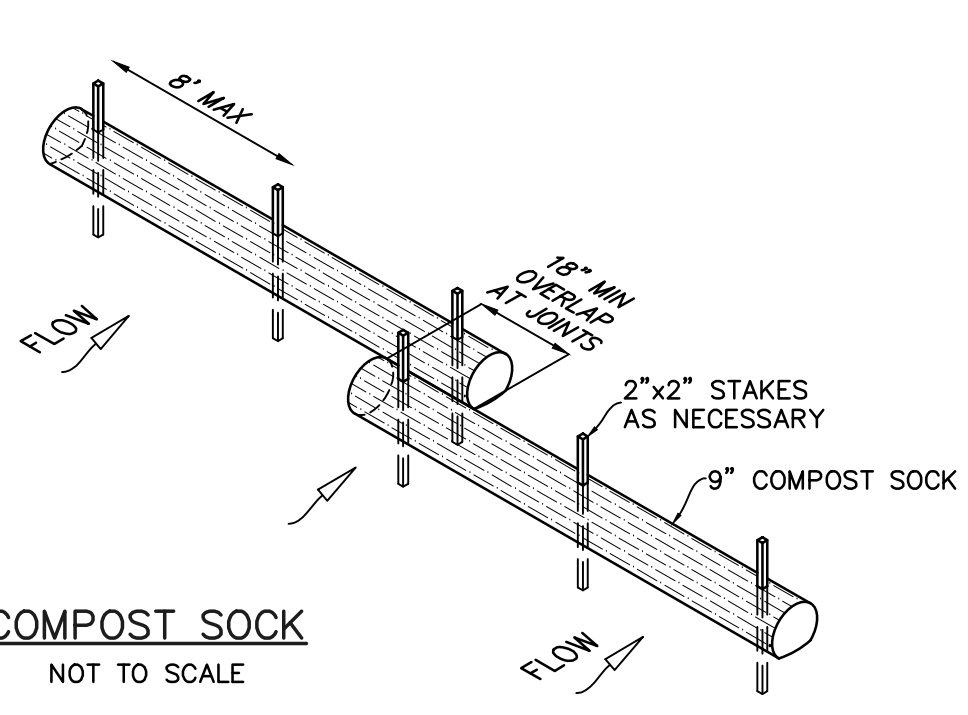

TOPOGRAPHIC SITE PLAN
NEEDHAM, MASSACHUSETTS
SHOWING PROPOSED CONDITIONS AT
#130 CLARKE ROAD
SCALE: 1in.=10ft. DATE: SEPTEMBER 28, 2021

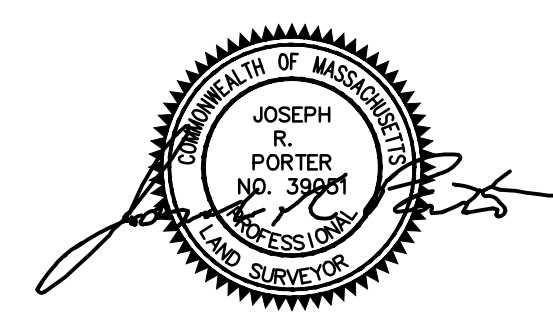

PROJECT: 220136
VTP
ASSOCIATES
INC.

LAND SURVEYORS - CIVIL ENGINEERS
132 ADAMS STREET 2ND FLOOR SUITE 3
NEWTON, MA 02458
(617) 332-8271